



**KIZILKAYA**

---

Product Catalog

*Since 1992* >>

## ABOUT US

---

Ömer KIZILKAYA, the founder of KIZILKAYA company, started his career in 1992 in one of Turkey's most respected and world-class brands in one of the leading companies in the sector. In this company, where he started his working life, he worked in different positions for the manufacture of Superpose, double break and semi-automatic rifles. He was appointed as the chairman of the board of directors in 2008 by the company's partners in this well-established company where he was working. He voluntarily resigned from this company, where he successfully served as the chairman of the board of directors for seven years, and from the position of chairman of the board of directors. Soon after, he and three other people founded a company for the joint production of shotguns. In this established company, it produced quality and high value-added rifles that had never been made in Turkey before, and sold them to different countries of the world.

KIZILKAYA, which has participated in many national and international fairs during these 30 years, has gained important experience about the situation, demands and all innovations of the sector in the world markets.

On the other hand, it has produced very different and very qualified products and has trained itself in this field with the experience and knowledge of having taken important roles at this point.

In order to transform its 30 years of knowledge and experience into a corporate value that it hopes to last for generations, it has enthusiastically entered into a new work by establishing KIZILKAYA Hunting and Sports Weapons Manufacturing Industry and Trade Limited Company.

The only goal of the established KIZILKAYA company is to become a world brand in the medium and long term by making high quality and qualified products. In line with this target, it continues on its way by working with great passion and enthusiasm.

*Since 1992*

# ***RT25*** SERIES

*Competition*



# Competition **RT25 SW**



<b>System:</b> 2 Shots	<b>Barrel Length:</b> 76/81 cm - 30/32 inch	<b>Chamber:</b> 2"3/4 inch - 70 mm	<b>Choke:</b> Mobile Choke	<b>Caliber:</b> 12
<b>Rib:</b> 10*10 mm	<b>Trigger Weight:</b> 1300/1600 gr	<b>Trigger Group:</b> Removable	<b>Weight:</b> 3850/3950 gr	<b>Stock:</b> #3 Turkish Walnut

## **RT25 SW PHOTOS**



IN ADDITION TO ITS IMPRESSIVE AND AESTHETIC APPEARANCE, THE RT25 HAS UNDOUBTEDLY TAKEN ITS PLACE AMONG THE BEST WITH ITS SUPERIOR TECHNICAL FEATURES.

# Competition **RT25 SLX**

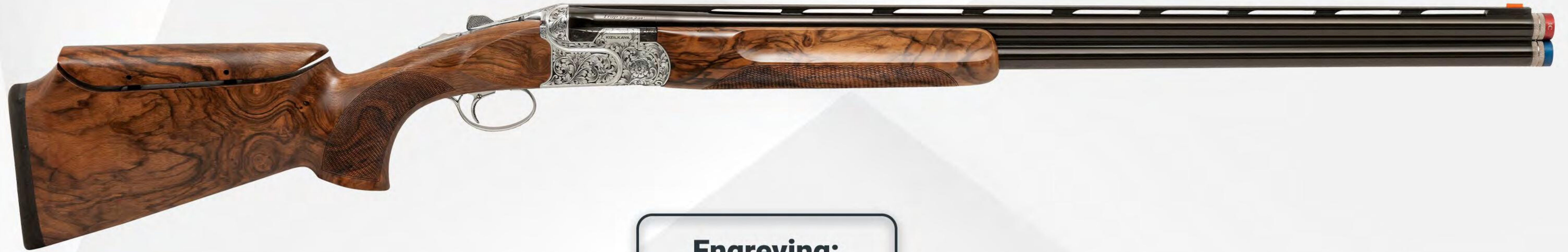

**Engreving:**  
*Hand Made*

**System:**  
2 Shots

**Barrel Length:**  
76/81 cm - 30/32 inch

**Chamber:**  
2<sup>3</sup>/<sub>4</sub> inch - 70 mm

**Choke:**  
Mobile Choke

**Caliber:**  
12

**Rib:**  
10\*10 mm

**Trigger Weight:**  
1300/1600 gr

**Trigger Group:**  
Removable

**Weight:**  
3850/3950 gr

**Stock:**  
#3 Turkish Walnut

**Engreving:**  
Hand Made

# ***RT25* SLX PHOTOS**



# Competition **RT25 SB**



**System:**  
2 Shots

**Barrel Length:**  
76/81 cm - 30/32 inch

**Chamber:**  
2<sup>3</sup>/<sub>4</sub> inch - 70 mm

**Choke:**  
Mobile Choke

**Caliber:**  
12

**Rib:**  
10\*10 mm

**Trigger Weight:**  
1300/1600 gr

**Trigger Group:**  
Removable

**Weight:**  
3850/3950 gr

**Stock:**  
#3 Turkish Walnut



# ***RT25* SB PHOTOS**



## RECEIVER & BARREL BLOCK



Receiver and barrel Blocks are one of the most important parts of the shotgun, along with the barrels. These two parts are very important to the life of the shotgun. After a certain number of shots, gaps occur in the shotgun due to wear. These gaps that occur not only negatively affect the sensitivity of your shotgun, and also negatively affect the psychology of the shooter. However, if these two parts are made of the right material and with precision, this wear can be delayed much more. These two parts of the RT25 are processed using the machining method from the 4140 coded solid mass material, which is also very qualified, in computer-controlled machines, taking into account the necessary sensitivities. The parts coming out of the machines take their final shape in the hands of experienced craftsmen with meticulous and flawless workmanship. When you own an RT25, you can have no doubt that you will have one of the strongest rifles in the world.

## BARREL TECHNICAL DETAILS

Barrels are one of the most important parts of the shotgun. Therefore, the material used, the method of manufacture and its dimensions are very important. For an optimum dispersion of pellets and a comfortable shot are required for a decisive victory for the shooter. The weight, balance and dimensions of the barrel are very important in order to provide these sensitive criteria to the shooter. In order to accurately capture these dimensions, the right material is absolutely needed. We use 4140 coded special alloy material, which is the most ideal material, for the barrel of RT25. We manufacture this qualified material in accordance with the desired dimensions and weights in computer-controlled precision machines by drilling with the deep drilling method. After this important material selection and equally sensitive measurements, another important issue is the coating of the barrel. Barrels with precise dimensions need a good coating against all kinds of wear and tear that they will suffer from for long years of shooting and external factors. The inside of the RT25's barrels is white glossy hard chrome plated. The outside of these barrels is again black hard chrome plated. Thanks to these coatings, it has been made resistant to all kinds of wear for many years. Thanks to the barrels manufactured with all these sensitivities in mind, you can be sure that your rifle has a good barrel.



## STOCK MEASUREMENT TABLE



**Standard Stock:** It is the standard stock used in our trap, skeet and sporting models. It has different sizes for Trap, Skeet and Sporting models. It is produced in the most suitable dimensions with reference to the average dimensions of world standards.



**Monte Carlo Stock:** Can be preferred for Trap models according to demand

STOCK MEASUREMENT TABLE- DİPÇİK ÖLÇÜ TABLOSU (mm)							
	A	B	C	D	E	F	G
TRAP STANDART	32	42		370	80	5	10
TRAP MONTECARLO	41	45	65	370	75	6	12
SPORTING STANDART	38	58		370	80	5	10
SPORTING MONTECARLO	41	47	57	370	75	6	12
20 HIGH RIB (Montecarlo)	37	44	64	370	75	6	12
12 HIGH RIB (Montecarlo)	37	44	64	370	75	6	12

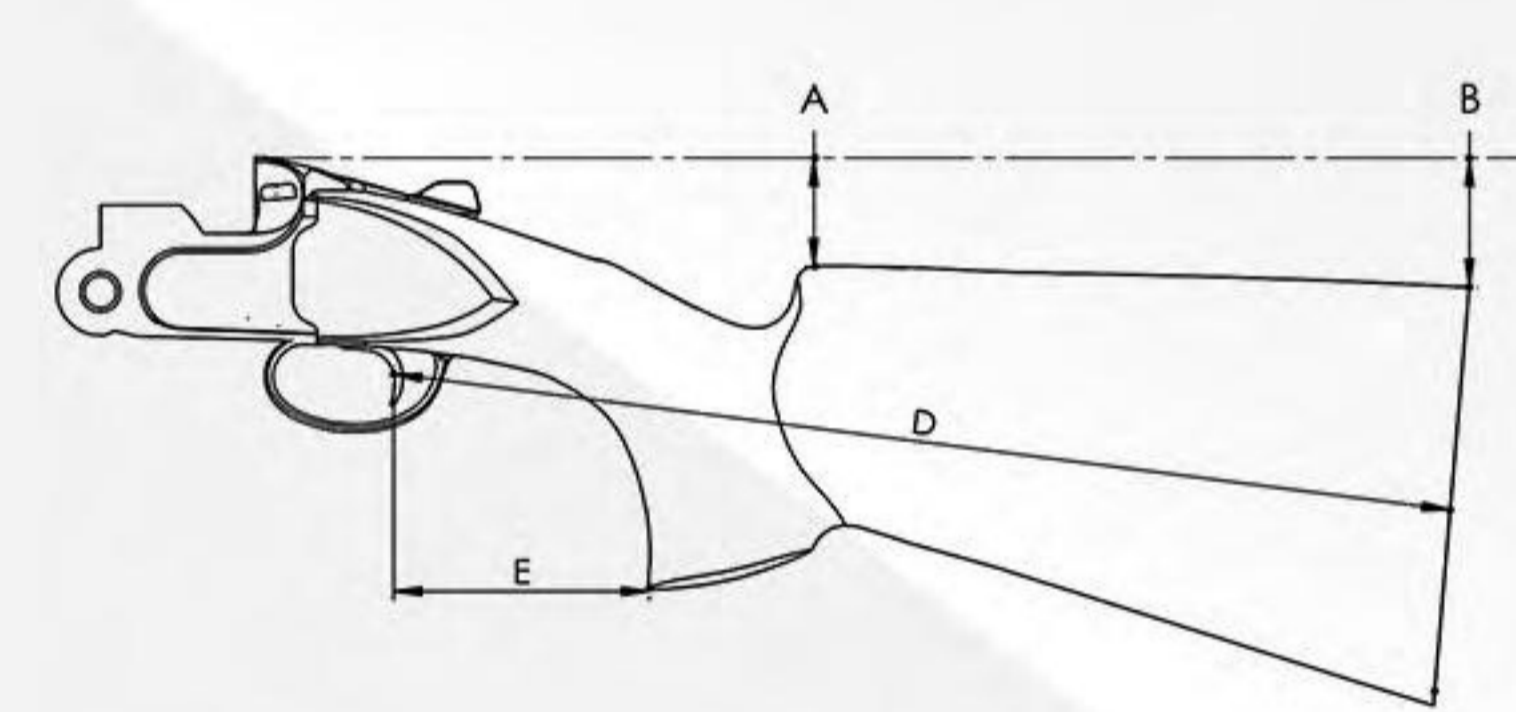

Standard Stock

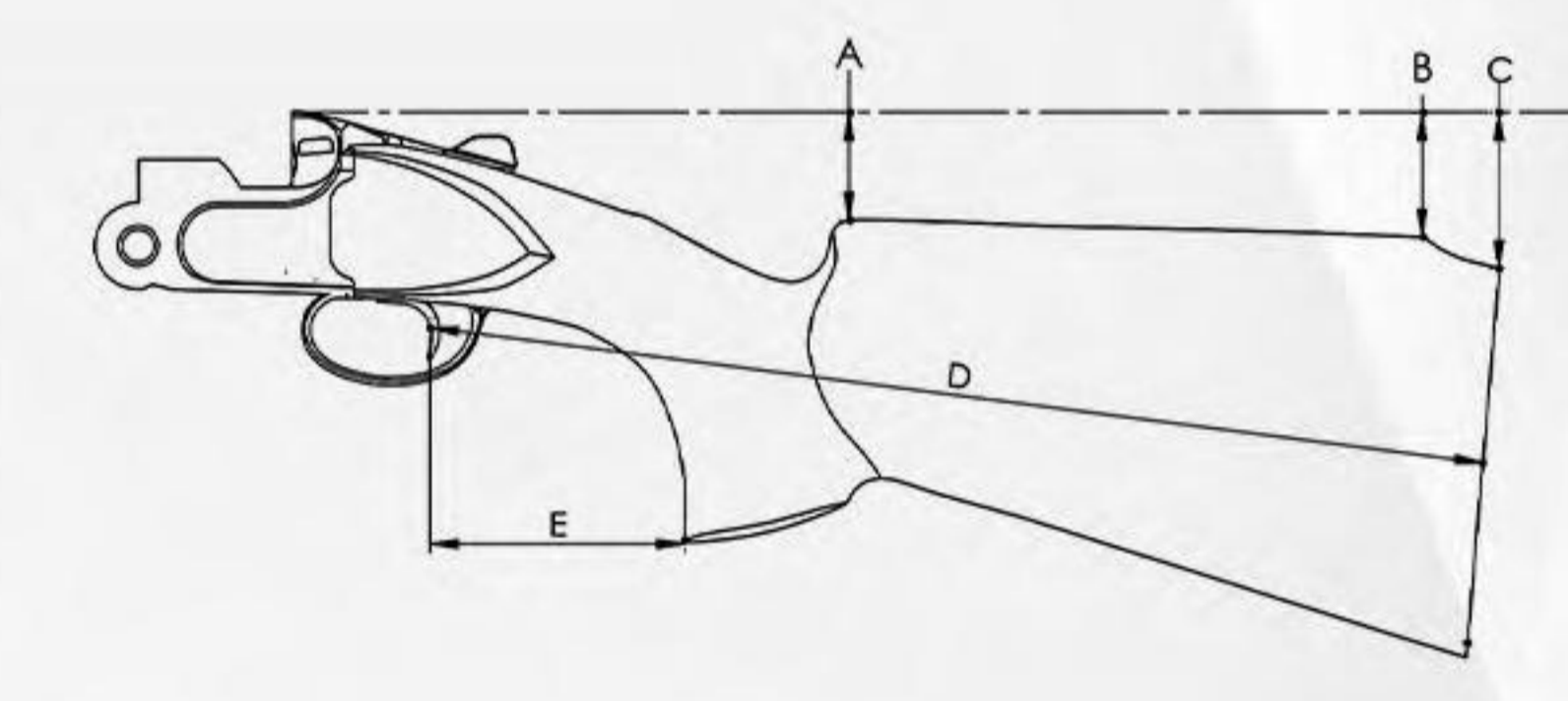
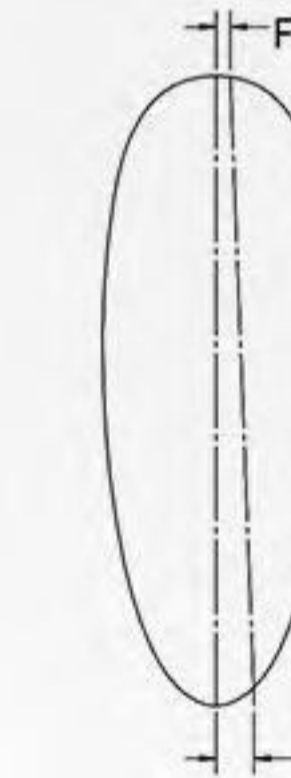

Monte Carlo Stock

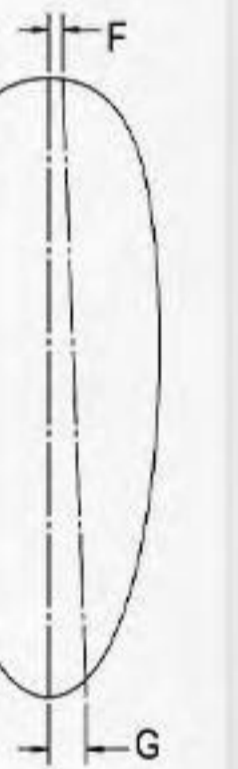

## FOREND TYPES



**Standard Forend:** It is the standard forend used in our trap models.



**Shanebel Forend:** It is the standard forend used in our Sporting and Skeet models.

### CHOKE TYPES AND MEASUREMENT TABLE

Standard Choke



Extended Choke



NAMLU ŞOK ÖLÇÜ TABLOSU- BARREL CHOKE SIZE CHART

NAMLU ŞOK ÖLÇÜ TABLOSU- BARREL CHOKE SIZE CHART									
---	--	--	--	--	--	--	--	--	--

SABİT ŞOK - FIXED CHOKE

SABİT ŞOK - FIXED CHOKE									
10/10	9/10	8/10	7/10	6/10	5/10	4/10	3/10	2/10	1/10
17,60	17,70	17,80	17,90	18,00	18,10	18,20	18,30	18,40	18,50

STANDART MOBİL ŞOK - STANDARD MOBILE CHOKE

STANDART MOBİL ŞOK - STANDARD MOBILE CHOKE										
I	II	III	IIII							
17,60	17,80	18,00	18,20	18,40						

UZATMA MOBİL ŞOK - EXTENDED MOBILE CHOKE

UZATMA MOBİL ŞOK - EXTENDED MOBILE CHOKE									
F	IM	M	IC	C					
17,60	17,80	18,00	18,20	18,40					

**NOTE:** Barrel inner width (inner diameter) 18,60 mm

**NOT:** Namlu iç genişliği (iç çap) 18,60 mm

### RIB MEASUREMENT TABLE

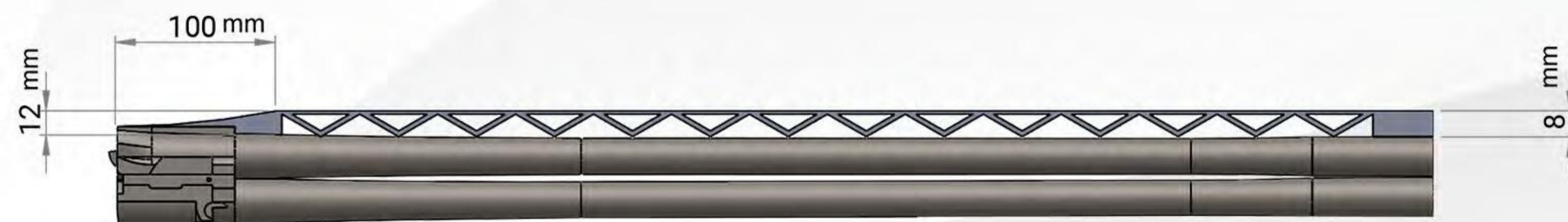

Medium Rib

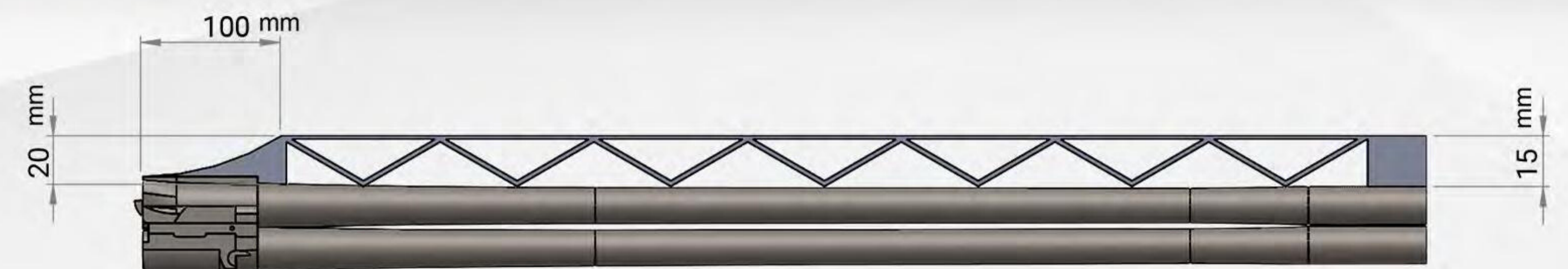

High Rib

## HAMMER SPRING

The hammer spring we use in all our models has two important features.

- It provides the shooter with an extremely clear trigger breakage
- Rooster drop speed is at maximum level.

These two features are of great importance for the shooter to shoot successfully.



## TRIGGER BODY



The trigger body is very important for a perfect shot. The trigger of a competition shotgun must have the right weight and sharp break. These two factors significantly affect the shooter's success rate in hitting the target, as they affect the stress on the finger muscle during the shooter's shooting. The RT25 has a trigger weight between 1500 and 1600 grams. This weight is accepted by shooters. In addition, the fact that the part angles in the trigger mechanism of the RT25 have been designed and manufactured in the most accurate way provides a sharp and clear trigger break to the RT25. One of the important features of the RT25 is that it has a trigger group system that can be easily removed without the need for any equipment during the trigger failure that may occur during the competition, although it is rare. In addition, the RT25's trigger has a functional feature that provides the shooter with the most ideal trigger distance thanks to its 10 mm movement in the forward and backward directions.

## OTHER PHOTOS





[www.kizilkaya.es](http://www.kizilkaya.es)